

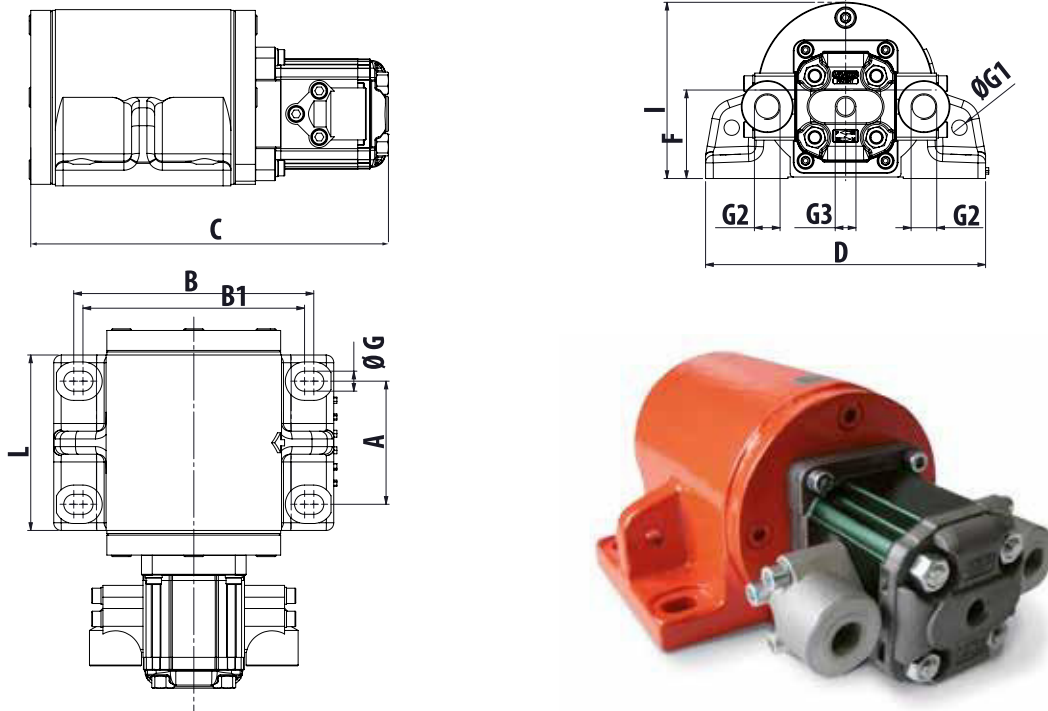

MVO - Hydraulic vibrators



DIMENSIONAL SPECIFICATIONS

A		B		B1		C		D		L		F		G		G1		G2		G3		I		Weight	
mm	in	mm	in	mm	in	mm	in	mm	in	mm	in	mm	in	mm	in	mm	in	BSPP	BSPP	mm	in	kg	lb		
80	3.2	156	6.1	144	5.7	233	9.2	182	7.2	115	4.5	58	2.3	13	0.5	10	0.4	3.8"	1/4"	114.5	4.50	11	24		

MECHANICAL FEATURES

MODEL	CENTRIFUGAL FORCE				WORKING MOMENT		STATIC MOMENT		OPERATING PRESS.		MAX PRESSURE	
	3000 rpm		6000 rpm		kgcm	inlb	kgcm	inlb	bar		bar	
	kg	lb	kg	lb					3000 rpm	6000 rpm		
	MVO 850	208	459	830	1830	4.12	3.57	2.06	1.78	70	120	

BEARING LIFE

rpm	CENTRIFUGAL FORCE		BEARING LIFE
	kg	lb	hrs
	3000	208	459
6000	830	1830	6,826

MVO - HYDRAULIC VIBRATORS

APPLICATION	Dump trailer - agriculture machine - digging bucket
POWDER	Hygroscopic - wet sticky and granular
PROBLEM SOLVING	Detaching

FEATURES

DUTY CYCLE	Continuous - S1
WORKING PRESSURE	From 15 bar to 300 bar (from 217 psi to 4.350 psi)
HYDRAULIC CIRCUIT	Flow control valve + filter (mesh 30-60 micron)
ENGINE SIZE	3.12 Cm ³ /round
WORKING TEMPERATURE	From -20 °C to 60 °C (from -4 °F to 140 °F)
OIL VISCOSITY	From 20 mm ² /sec to 100 mm ² /sec
OIL TYPE	HLP HV (D in 51524) hydraulic mineral oil
FLOW RATE	2,24 l/min (700 rpm) - 9,6 l/min (3.000 rpm) - 19,2 l/min (6.000 rpm)
MAX NOISE LEVEL	80 dB(a)
MOTOR TYPE	XV-1M/3.2
TECHNOLOGY	Hydraulic rotary vibrator
MATERIAL	Grey cast iron body (RAL 2004 powder painted)

This information is furnished without warranty, representation, inducement or license of any kind. It is accurate to the best OLI knowledge or is obtained from sources believed to be accurate. OLI therefore assumes no legal responsibility.

